

RAPPORT DE SPÉCIFICATIONS DE PRODUIT

NOM DU PROJET: _____

INFORMATION SUPPLÉMENTAIRE: _____

QUANTITÉ REQUISE: _____

NUMÉRO DE PRODUIT: **83433A**

DÉTAILS DU PRODUIT

- **Type de luminaire:** Murale extérieure
- **Largeur:** 7 7/8" (200 mm)
- **Hauteur:** 13 3/4" (350 mm)
- **Profondeur:** 5 5/8" (143 mm)
- **Poids:** 5.952 lbs. (2.700 kgs.)
- **Puissance en watts (maximum):** 1 x 100W
- **Type d'ampoule:** A19
- **Fini:** Anthracite
- **Verre:** Blanc
- **Matériel:** Acier avec abat-jour en verre
- **Type d'installation:** Relié à la boîte électrique

CERTIFICATION

- c-UL-us et c-ETL-us Liste

FEUILLES D'INSTRUCTIONS

- Français et anglais inclus

AUTRES INFORMATIONS

- **UPC:** 9008606018383
- **Nom du produit:** Park
- **Verre de Remplacement:** GL-803

PHOTO



DESSIN DE LIGNE

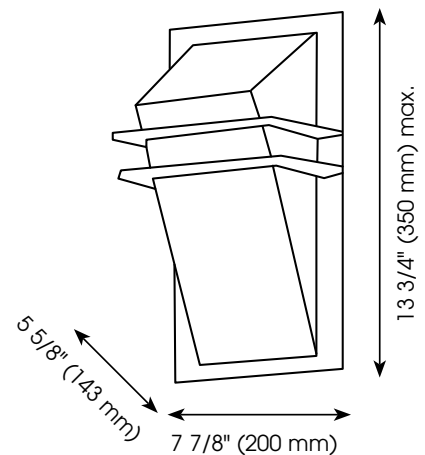

EGLO Canada



PRODUCT SPECIFICATIONS REPORT

PROJECT NAME: _____

ADDITIONAL INFORMATION: _____

QUANTITY REQUIRED: _____

PRODUCT NUMBER: **83433A**

PRODUCT DETAILS

- **Fixture Type:** Outdoor Wall Light
- **Width:** 7 7/8" (200 mm)
- **Height:** 13 3/4" (350 mm)
- **Depth:** 5 5/8" (143 mm)
- **Weight:** 5.952 lbs. (2.700 kgs.)
- **Bulb Wattage (maximum):** 1 x 100W
- **Bulb Type:** A19
- **Finish:** Anthracite
- **Glass:** White
- **Material:** Steel with Glass Shade
- **Installation Type:** Hardwire (Standard 4" Outlet Box)

PHOTO



LINE DRAWING

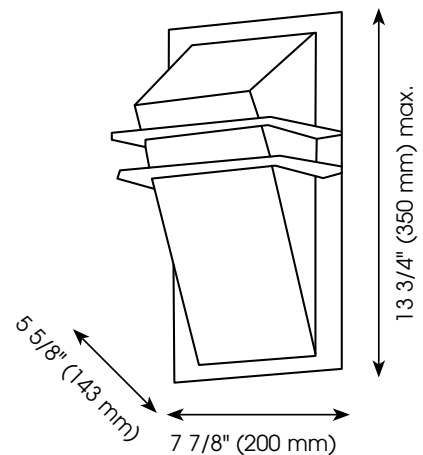

SAFETY LISTING

- c-UL-us and c-ETL-us Listed

INSTRUCTION SHEETS

- Included in English & French

OTHER INFORMATION

- **UPC:** 9008606018383
- **Series Name:** Park
- **Glass Replacement:** GL-803

EGLO Canada

