

RAPPORT DE SPÉCIFICATIONS DE PRODUIT

NOM DU PROJET: _____

INFORMATION SUPPLÉMENTAIRE: _____

QUANTITÉ REQUISE: _____

NUMÉRO DE PRODUIT: **93316A**

DÉTAILS DU PRODUIT

- **Type de luminaire:** Murale extérieure DEL
- **Largeur:** 9 5/8" (243 mm)
- **Hauteur:** 6 3/4" (170 mm)
- **Profondeur:** 3 1/4" (84 mm)
- **Poids:** 2.969 lbs. (1.347 kgs.)
- **Puissance en watts (maximum):** 2 x 2.5W
- **Type d'ampoule:** DEL
- **Lumens:** 360
- **Kelvin:** 3000K
- **Fini:** Acier poli et blanc
- **Matériel:** Acier
- **Type d'installation:** Relié à la boîte électrique

CERTIFICATION

- c-UL-us et c-ETL-us Liste

FEUILLES D'INSTRUCTIONS

- Français et anglais inclus

AUTRES INFORMATIONS

- **UPC:** 9008606133246
- **Nom du produit:** Esparta
- **Verre de Remplacement:** N/A

PHOTO

LED
WHITE
LED
BLANC



DESSIN DE LIGNE

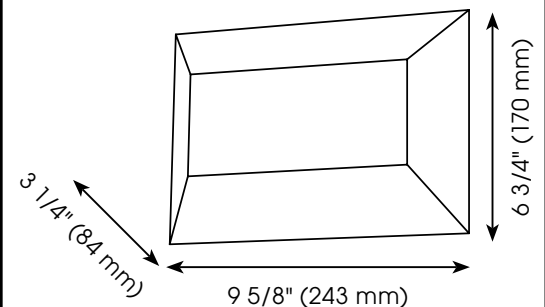

EGLO Canada



PRODUCT SPECIFICATIONS REPORT

PROJECT NAME: _____

ADDITIONAL INFORMATION: _____

QUANTITY REQUIRED: _____

PRODUCT NUMBER: **93316A**

PRODUCT DETAILS

- **Fixture Type:** LED Outdoor Wall Light
- **Width:** 9 5/8" (243 mm)
- **Height:** 6 3/4" (170 mm)
- **Depth:** 3 1/4" (84 mm)
- **Weight:** 2.969 lbs. (1.347 kgs.)
- **Bulb Wattage (maximum):** 2 x 2.5W
- **Bulb Type:** LED
- **Lumens:** 360
- **Kelvin:** 3000K
- **Finish:** Polished Steel & White
- **Material:** Steel
- **Installation Type:** Hardwire (Standard 4" Outlet Box)

PHOTO

LED WHITE LED BLANC

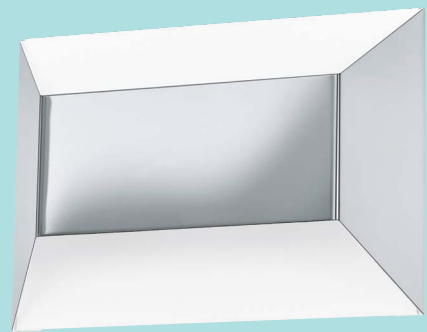

LINE DRAWING

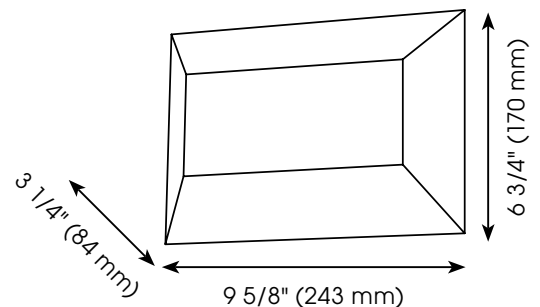

SAFETY LISTING

- c-UL-us and c-ETL-us Listed

INSTRUCTION SHEETS

- Included in English & French

OTHER INFORMATION

- **UPC:** 9008606133246
- **Series Name:** Esparta
- **Glass Replacement:** N/A

EGLO Canada

